

Digital Pressure Gauge XY-PG300E

Typical Feature

- Dial diameter 100 mm
- With 4-Digits LED Display.
- Accuracy level: 0.5% FS
- Wide measurement pressure range(0~160MPa), or customized
- Powered 12VDC,24VDC or 220VAC and 380VAC are optional
- Multi pressure multiunit switching (PSI/Kg.F/cm²/MPa)
- One key reset



Brief Introduction





XY-PG300E is Digital Pressure Gauge with LED Display, which was built-in high accuracy pressure sensor, it displays real time pressure at short response time, the typical characteristics are high accuracy and excellent long-term stability, designed for Pressure Container, Air Compressor, Automated Machine, Heat Pump Industry, it's very good alternative for Mechanical Pressure Gauge.

The Digital Pressure Gauge has LED display with 4-Digits. There are 2 buttons on front panel to control Reset, unit converting. It is easy to install in Pipeline, Isolation Tank or Others connects device, easy to set up operating parameter. Working condition is -20~80°C.

It has 304 stainless steel shell and connect joint, can be used in measuring gas, liquid, oil and other medium; it has very good shock resistance and long working life.

XY-PG300E Digital Pressure Gauge is powered by 12VDC or 24VDC;220VAC and 380VAC are optional. There are wide measurement range from 0-160MPa, others Measurement Ranges are optional. Machinal joint include Thread, Flush Diaphragm, Clamp, Flange, Radiator and Differential Two-way Fitting.

Suggested Applications

-  Pressure Container,
-  Air Compressor
-  Automated Machine
-  Heat Pump Industry
-  Customized Applications

More details for XY-PG300E, please contact us.

Specification

Model	XY-PG300E
Gauge Pressure Range	0~100KPa~1MPa~1.6~5~10~25~40~160MPa
Pressure Type	Gauge Pressure Test
Dimension	Diameter Φ100
Overload Capacity	150%
Measurement Medium	Gas or oil or other Liquid with Compatibility of SS 304
Accuracy Level	0.5%FS;
Long-Term Stability/Year	Typical: ±0.5% FS;

Sample Frequency	5 times/Second
Display	4 digits LED
Operating temperature	-20~80°C
Compensation Temperature	-10~60°C
Power Supply	12VDC or 24VDC; 220VAC and 380 are optional
Power	≤0.5W

Dimension(mm)

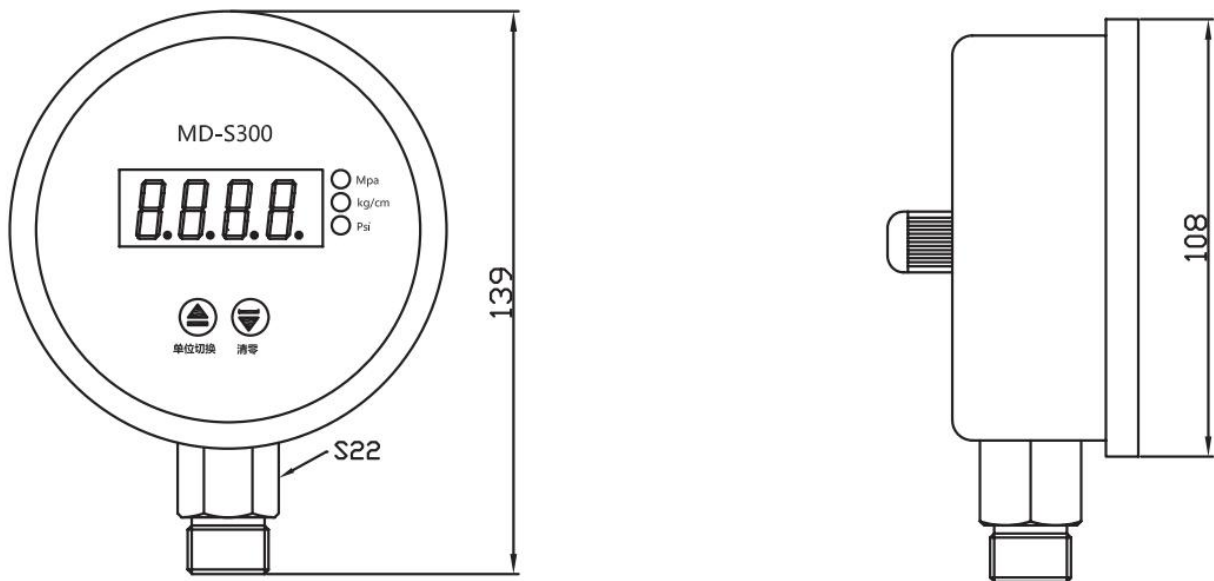

Mechanical Connection(mm)

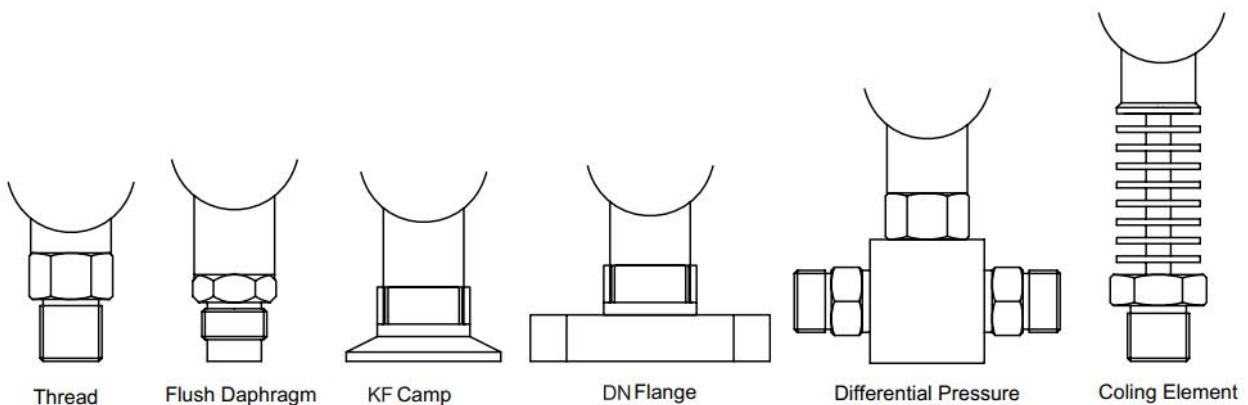

How To Order

XY	PG	280	E	P	60M	1	P2	J	M3	B1	T1	L	
	Category	Type	Setup	Pressure Connection	Pressure Range	Accuracy	Power	Output	Thread	Electrical Connection	Medium Temperature	Additional	
PG	Pressure Gauge	280 High Accuracy	E Lower Mount	None General Thread	1K (0-10Pa)	1 0.40%	P0 Battery	R RS485	M1 M20*1.5	B Cable Outlet	T1 -5~40°C	LC LCD Display	
		210 High Accuracy Pressure&Temperature	Z Panel Mount	P Diaphragm Seals	1B (0-1Bar)	2 0.20%	P2 24V	A 4-20mA	M2 G1/4	C Circular Connector	T2 -20~80°C	LE LED Display	
		270 Explosion-Proof	G Wireless	DP Differential Pressure	1M (0-1MPa)	3 0.10%	P4 120V	J1 Relay	M3 G1/2	CC Customized	T3 Customized	TI Explosion-Proof	
		280 80mm Dial Size LCD Display	F Peak Record	VF Clamp	OC Customized	4 0.50%	P5 280V	J2 Dual Relay	M4 1/20PT				
		260 60mm Dial Size	V Vacuum Switch	DN Flange		5 0.25%	P6 12V	CC Customized	M5 1/40PT				
		380 100mm Dial Size	W Water Pump Switch	9999 Customized		9 Customized	P9 Customized		M7 G1/4				
		380 80mm Dial Size LED Display							M9 Customized				
		360 Digital Remote Transmission											
		625 Contact 60mm Dial Size											
		825 Contact 80mm Dial Size											
		925 Contact 90mm Dial Size											
		PS	Pressure Switch	630 60mm Dial Size									
828 80mm Dial Size													
928 100mm Dial Size													
650 Switch Box with Plastic Shell													
660 Switch Box with Full Metal Shell													
PC	Pressure Control	680 60mm Dial Size											
		880 80mm Dial Size											
		980 100mm Dial Size											

Remark 1. This form is for whole Pressure Measurement and Pressure Control products, please read Product Date Sheet to get reference informations
2. If you may not find right information in this form, Please contact us to get future details

Shanghai XuYan Precision Technology Co., Ltd.

Address: No. 969, YunHan Road Pudong District Shanghai City China

Tel: +86 21 59241315

Email: sales@xvyanprecision.com

Website: www.xvyanprecision.com

Product Manager: Tyler Tou

Cell: +86 189 1797 0680

Email: ttao@Xuyanpercision.com